

Tecnologia “Senza leva”, applicata a una torretta, che **elimina in maniera definitiva lo sforzo fisico** dell'operatore mantenendo invariati sia la procedura che i movimenti di lavoro nello smontaggio del pneumatico (**Brevettato**).

La procedura di montaggio mantiene invariati i movimenti, la **praticità** e la **velocità** di esecuzione.

“Without lever” technology, applied to a tool head, that **permanently eliminates operator's physical strain** while keeping both tyre demounting work procedure and movements unchanged (**Patented**).

The assembly procedure movements remain the same just like its **easy-to-use** and **execution speed features**.

Dati tecnici Technical data

Presca esterna	Outside Clamp	11”- 24”
Presca interna	Inside Clamp	13”- 26”
Diametro max. ruota	Max. wheel diameter	1100 mm
Larghezza pneumatico	Tire Width	4”- 14”
Apertura stallonatore	Bead-breaker opening	380 mm
Potenza stallonatura	Bead-breaking power	15000 N
Pressione di esercizio aria	Working air Pressure	8 - 10 bar
Potenza motore	Motor Power	400V - 3ph - 0,75 kW 200/230V - 3ph - 0,75 kW 400V - 3ph - 2V - 0,85/1.1 kW 200/230V - 1ph - 1.1 kW 100/115V - 1ph - 1.1 kW
Velocità rotazione mandrino	Chuck rotation speed	7 rpm - 2V 6.5 -13 rpm
Rumorosità durante il funzionamento	Noise level running	<70 dB
Peso netto macchina	Nett Weight machine	270 kg
Peso lordo macchina	Gross Weight machine	310 kg
Dimensione max imballo (LxPxH)	Max Dimension Imballage (LxPxH)	1150x920x1000 mm
per contenitore da 40”	for 40” container	46 pcs

Dotazione Equipment

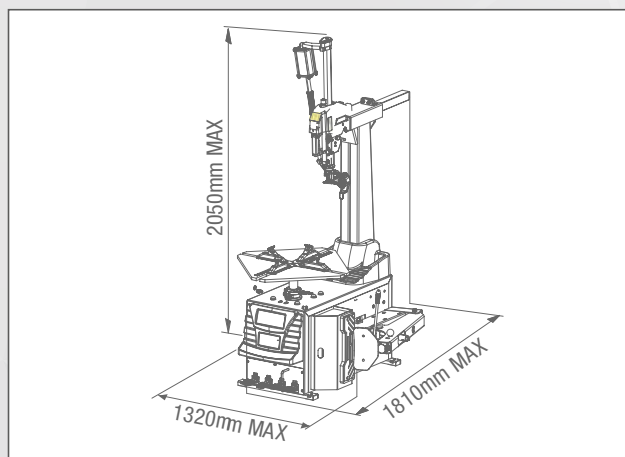
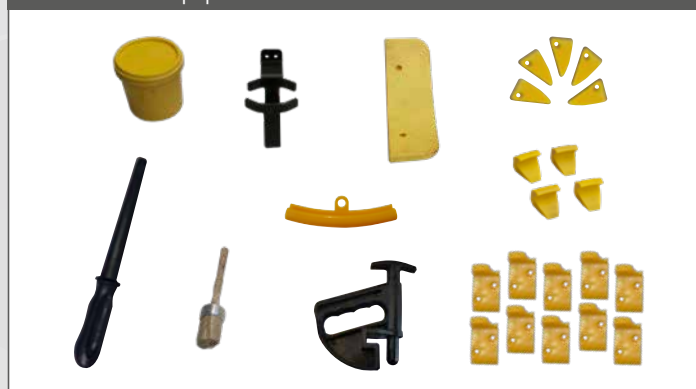

Accessori Accessories

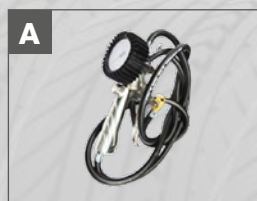

A -> 8-11100362

- EC Asturo pistol - EC approved: ad esclusione delle versioni TI
- EC Asturo pistol - EC approved: except for TI versions

B -> CT-S-0600000

- Supporto rotazione ruota WRSB
- Wheel rotation support WRSB

C. -> 8-11120075

- Sollevatore ruota FWL 65
- Wheel lifter FWL 65

S 524 LL

STARTLINE

NEW

24"



*HTB24 helper a richiesta - *helper optional* code 8-11900260

Assolutamente consigliato - Absolutely recommended

Smontagomme automatico "Senza leva" per autovetture e trasporto leggero

Automatic "without lever" tyre changer for cars and light duty vehicles



automotive service equipment